



TGX-600S

Pressures to 10,000 PSI
Flows to 274 GPM • Power to 750 HP

Features

- ◆ Triplex (three plungers).
- ◆ Sectionalized “L” fluid end design/optional oilfield style fluid end.
- ◆ Pressure range to 10,000 PSI.
- ◆ Flow rates to 274 GPM / 1037 LPM.
- ◆ Maximum frame load of 100,000 Lbs. / 45360 Kg.
- ◆ Stainless steel fluid end construction.
- ◆ Manufactured on state-of-the-art machinery.
- ◆ Rigorously subjected to full load testing.
- ◆ Designed for continuous service.
- ◆ Easy field maintenance.
- ◆ Field proven design.
- ◆ Extremely reliable.

Applications

- ◆ Water Blasting
- ◆ Concrete Demolition
- ◆ Hydrostatic Testing
- ◆ Process Water Disposal



Performance Specifications

TGX-600S	MAX. PRESSURE	FLOW								
		PLUNGER DIA.	80 RPM		160 RPM		300 RPM		365 RPM	
			PSI/BAR	GPM/LPM	PSI/BAR	GPM/LPM	PSI/BAR	GPM/LPM	PSI/BAR	GPM/LPM
	3.500" - 88.9mm	10K/689	60/227	10K/689	120/454	5.3K/365	225/851	4.3K/296	274/1037	

Stroke: 6" / 152.4 mm • Max. Speed: 370 RPM • Weight: 8,500 Lbs. / 3856 Kg

Note: Pump is equipped with reduction gear.

Note: All flows are based on 100% volumetric efficiency. Pressures shown are based on single-speed performance. See unit specification sheets for pressure ratings on multi-speed units.

All flows realized will vary dependent upon several factors, such as but not limited to: pump speed, pump pressure, plunger size and pumped fluid.

“Typical” actual flow rates will be approximately 95% of values shown above.



GARDNER DENVER WATER JETTING SYSTEMS, INC.

Partek • Liqua-Blaster • CRS Power Flow • Jetting Systems • American Water Blaster

TGX-600S PUMP

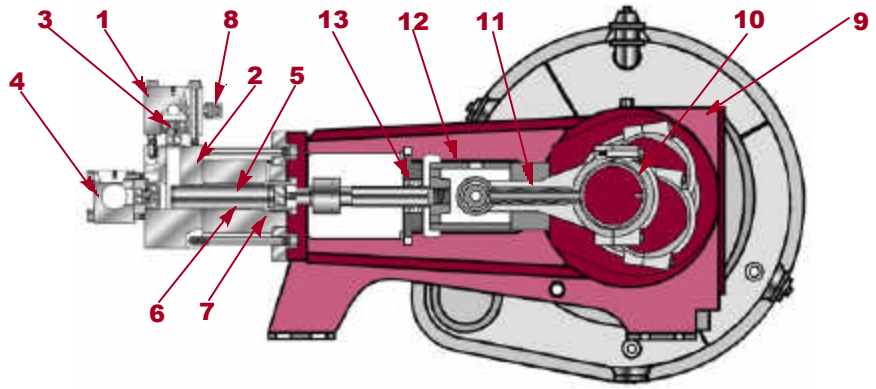

Fluid End

1. **Discharge Manifold:** Manufactured from precipitation hardened stainless steel.
2. **Fluid Cylinder Body:** Three cylinders machined from hardened stainless steel and autofrettaged for extended life.
3. **Valves:** Hardened stainless steel, autofrettaged for extended life. Valves are spring-loaded for positive closing with a common seat used for both suction and discharge valves. Valves have a replaceable elastomer insert for solid sealing when pmping abrasive liquids.
4. **Suction Manifold:** Electroless nickel plated coated carbon steel.
5. **Plungers:** Stainless steel with colmony coating.
6. **Plunger Packing:** Carbon filled Teflon™ and polyethylene base, spring loaded, self-adjusting and easily replaceable from the rear of the stuffing box. Force-fed oil lubrication.
7. **Stuffing Boxes:** Machined from heat treated stainless steel.

8. **Pressure Relief:** Standard equipment includes a relief valve and a pressure safety head assembly (rupture disc) mounted to the discharge manifold.

Power End

9. **Power Frame:** Manufactured from precision machined alloy steel.
10. **Crankshaft:** Single extended forged alloy steel with tapered roller bearings to minimize side thrust load. Drilled for forced oil lubrication.
11. **Connecting Rods:** Ductile iron with automotive type split insert bearings.
12. **Crossheads:** Large, piston type constructed of gray iron.
13. **Diaphragm Seals:** Installed with o-rings or gaskets and neoprene oil seals.

Reduction Gear: Constructed of top quality AGMA Class 12 steel. Hardened and ground bull and pinion gears for strength and durability. Ratio available - 5.74:1.

Dimensions TGX-600S

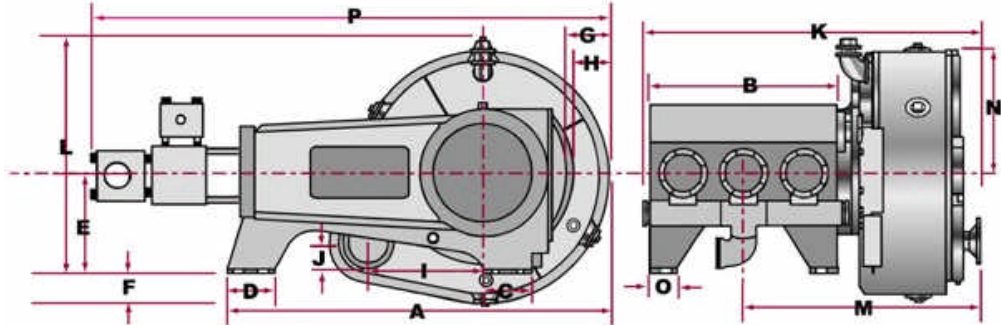

	A	B	C	D	E	F	G	H	I	J	K	L	M	N	O	P
in.	67 ¹ / ₂	34 ¹ / ₄	8 ³ / ₈	8 ³ / ₈	17 ³ / ₄	5 ¹ / ₂	15 ¹ / ₂	14 ³ / ₄	20 ¹ / ₈	6 ¹ / ₈	62 ⁷ / ₈	41 ¹ / ₂	42 ⁷ / ₈	22 ¹ / ₄	5	90 ¹ / ₂
mm	1714.5	870	212.7	212.7	450.85	139.7	393.7	374.65	511.2	155.6	1597	1054.1	1089	565.15	127	2299

Gardner Denver Water Jetting Systems reserves the right to change specifications without notice.

**GARDNER DENVER
WATER JETTING
SYSTEMS, INC.**



GARDNER DENVER WATER JETTING SYSTEMS, INC.
Partek · Liqua-Blaster · CRS Power Flow · Jetting Systems · American Water Blaster