



# TGX-600HB

Pressures to 20,000 PSI  
Flows to 140 GPM • Power to 750 HP

## Features

- ◆ Inline fluid end design.
- ◆ Pressure range to 8,500 PSI.
- ◆ Flow rates to 140 GPM / 529.9 LPM.
- ◆ Maximum frame load of 100,000 Lbs. / 45360 Kg for multi-speed.
- ◆ Manufactured on state-of-the-art machinery.
- ◆ Designed for continuous service.
- ◆ Easy field maintenance.
- ◆ Stainless steel fluid end construction.
- ◆ Rigorously subjected to full load testing.
- ◆ Extremely reliable.
- ◆ Field proven design.

## Applications

- ◆ Water Blasting
- ◆ Concrete Demolition
- ◆ Hydrostatic Testing



## Performance Specifications

TGX-600HB	MAX. PRESSURE PLUNGER DIA. 2.500" - 63.5mm	FLOW							
		157 RPM		200 RPM		300 RPM		366 RPM	
		PSI/BAR	GPM/LPM	PSI/BAR	GPM/LPM	PSI/BAR	GPM/LPM	PSI/BAR	GPM/LPM
		20K/1379	60/227	15.5K/1068	77/291	10K/689	120/454	8.5K/586	140/530

Stroke: 6" / 152 mm • Max. Speed: 370 RPM • Weight: 8,300 Lbs. / 3765 Kg

**Note:** Pump is equipped with reduction gear.

**Note:** All flows are based on 100% volumetric efficiency. Pressures shown are based on single-speed performance. See unit specification sheets for pressure ratings on multi-speed units.

All flows realized will vary dependent upon several factors, such as but not limited to: pump speed, pump pressure, plunger size and pumped fluid.



GARDNER DENVER WATER JETTING SYSTEMS, INC.

Partek • Liqua-Blaster • CRS Power Flow • Jetting Systems • American Water Blaster

# TGX-600HB PUMP

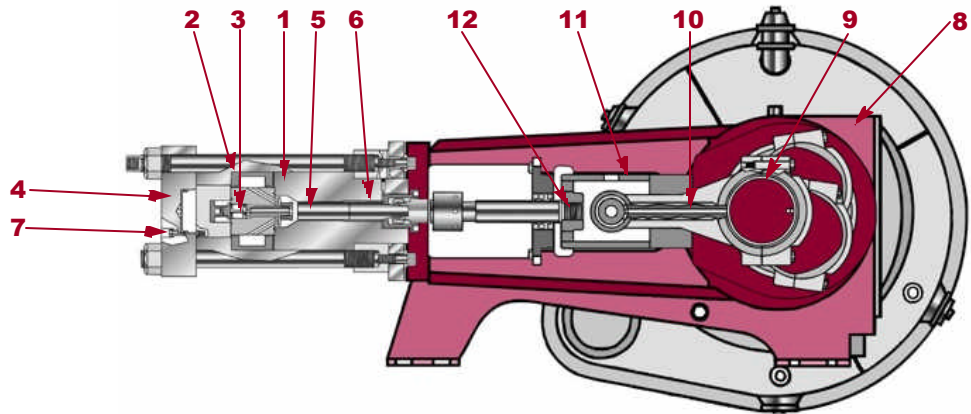

## Fluid End

1. **Fluid Cylinder Body:** Three cylinders machined from hardened stainless steel, autofrettaged for extended life.
2. **Suction Manifold:** Hard, anodized aluminum. Also available in stainless for salt water applications.
3. **Valve Assembly:** Hardened stainless steel, autofrettaged for extended life. Valves are spring-loaded for positive closing with a common seat used for both suction and discharge valves.
4. **Discharge Manifold:** Manufactured from precipitation hardened stainless steel.
5. **Plungers:** Collet style, made of coated tungsten carbide.
6. **Plunger Packing:** Carbon filled Teflon™ and polyethylene base, spring loaded, self-adjusting and easily replaceable from the rear of the stuffing box. Force-fed water provides lubrication and cooling.
7. **Pressure Relief:** Pressure safety head assembly (two rupture discs), mounted to the discharge manifold.

## Power End

8. **Power Frame:** Manufactured from a single piece casting of high strength gray cast iron.
9. **Crankshaft:** Single extended forged alloy steel with tapered roller bearings to minimize side thrust load. Drilled for forced oil lubrication.
10. **Connecting Rods:** Ductile iron with automotive type split insert bearings.
11. **Crossheads:** Large, piston type constructed of gray iron.
12. **Diaphragm Seals:** Installed with o-rings or gaskets and neoprene oil seals.

**Reduction Gear:** Constructed of top quality AGMA Class 12 steel. Hardened and ground bull and pinion gears for strength and durability. Ratios available - 5.74:1.

**Forced Oil Lubrication System:** Unique pump feature which allows oil to be forced through a rifle-drilled crankshaft lubricating each journal, connecting rod and wrist pin bearing.

## Dimensions TGX-600HB

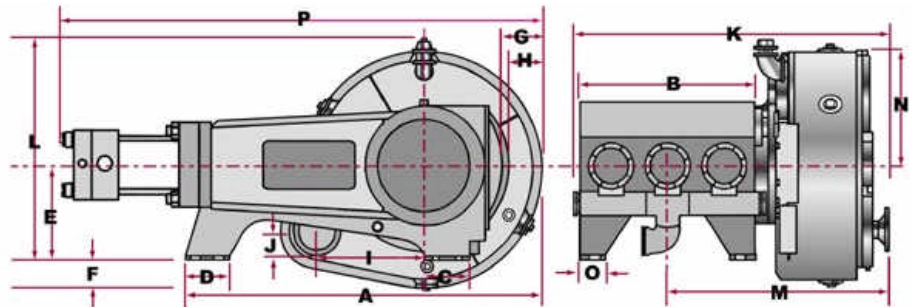

	A	B	C	D	E	F	G	H	I	J	K	L	M	N	O	P
in.	67 <sup>1</sup> / <sub>2</sub>	34 <sup>1</sup> / <sub>4</sub>	8 <sup>3</sup> / <sub>8</sub>	8 <sup>3</sup> / <sub>8</sub>	17 <sup>3</sup> / <sub>4</sub>	5 <sup>1</sup> / <sub>2</sub>	15 <sup>1</sup> / <sub>2</sub>	14 <sup>3</sup> / <sub>4</sub>	20 <sup>1</sup> / <sub>8</sub>	6 <sup>1</sup> / <sub>8</sub>	62 <sup>7</sup> / <sub>8</sub>	41 <sup>1</sup> / <sub>2</sub>	42 <sup>7</sup> / <sub>8</sub>	22 <sup>1</sup> / <sub>4</sub>	5	98 <sup>1</sup> / <sub>2</sub>
mm	165.1	870	212.7	212.7	450.85	139.7	393.7	374.65	511.2	155.6	1597	1054.1	1089	565.15	127	2502

Gardner Denver Water Jetting Systems reserves the right to change specifications without notice.

**GARDNER DENVER  
WATER JETTING  
SYSTEMS, INC.**



GARDNER DENVER WATER JETTING SYSTEMS, INC.

Partek · Liqua-Blaster · CRS Power Flow · Jetting Systems · American Water Blaster