

The AV Series

WORKS BEST UNDER PRESSURE

AV Oil Fired
Portable



AV NG/LP
Stationary



Best Engineered

VERSATILITY

The AV and AV NG/LP series are the most portable and maneuverable pressure washers in the industry. Versatility with features such as interchangeable wheel configurations allows you to accommodate your individual needs. These products are ideal for industrial and commercial cleaning applications.

SERVICEABILITY

RAMTEQ's top-quality, durable construction provides years of reliability. Designed with the user in mind, RAMTEQ's modular technology supports low operational costs through easy, efficient and effective service and upgrade paths. RAMTEQ products are designed and built for performance, dependability and low total cost of ownership.

VALUE

With RAMTEQ, you get more than just top-of-the-line products with the features and conveniences you want. You also get unmatched customer service and support from a company dedicated to innovative engineering and customer satisfaction.

NO WONDER CUSTOMERS
CHOOSE RAMTEQ.

Its Simply Done Right.™

RAMTEQ[®]
QUALITY PRESSURE WASHERS



**SPLIT STAINLESS-STEEL OUTER
COIL WRAP**
RELIABILITY

BALDOR® MOTORS
RELIABILITY

WAYNE® BURNERS
RELIABILITY

**ALTERNATE WHEEL
CONFIGURATIONS**
PORTABILITY—MANEUVERABILITY

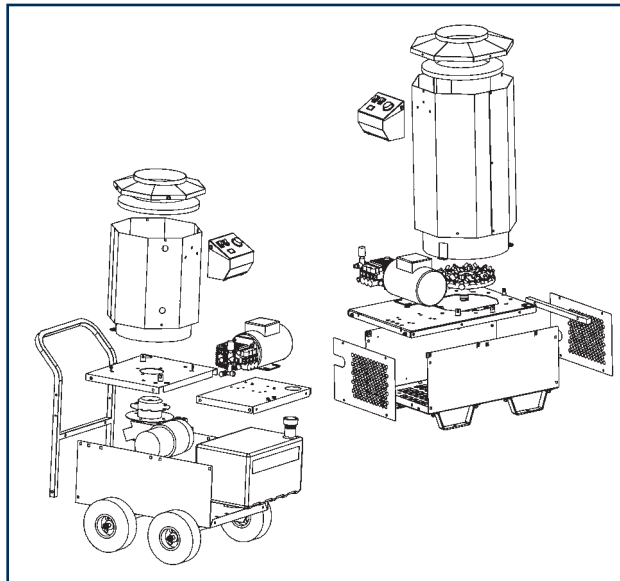

MODULAR DESIGN
SERVICEABILITY

**GENERAL® DIRECT DRIVE
TRIPLEX PLUNGER PUMPS**
RELIABILITY

**CROSS-LINKED
POLYETHYLENE FUEL TANK**
SAFETY—DURABILITY

**CHASSIS UNDERCARRIAGE
FOR FUEL TANK**
SAFETY

SPECIFICATIONS

	150 SERIES	200 SERIES	300 SERIES	500 SERIES
MOTOR HP	1.5 HP	2.0 HP	3.0 HP	5.0 HP
VOLTAGE/CYCLE/PHASE	115/60/1	115/60/1	208-230/60/1	208-230/60/1
WATER PUMP VOLUME	2.0 GPM/7.6 LPM	2.0 GPM/7.6 LPM	2.8 GPM/10.6 LPM	3.6 GPM/13.7 LPM
OPERATING PRESSURE	1,000 PSI/68.9 BARS	1,400 PSI/96.5 BARS 1,000 PSI/68.9 BARS	1,500 PSI/103.4 BARS	2,000 PSI/137.9 BARS
BTUS PER HOUR				
OIL FIRED	195,000	195,000	270,000	270,000
NATURAL GAS	210,000	210,000	310,000	310,000
LIQUID PROPANE	220,000	220,000	310,000	310,000
DIMENSIONS				
OIL FIRED	36.0" L, 28.5" W, 39.1" H	36.0" L, 28.5" W, 39.1" H	36.0" L, 28.5" W, 43.6" H	36.0" L, 28.5" W, 43.6" H
NATURAL GAS	30.0" L, 20.3" W, 39.9" H	30.0" L, 20.3" W, 39.9" H	30.0" L, 20.3" W, 46.3" H	30.0" L, 20.3" W, 46.3" H
GROSS SHIPPING WEIGHT:				
OIL FIRED	345 LBS	350 LBS	415 LBS	420 LBS
NATURAL GAS / LP	375 LBS	380 LBS	475 LBS	480 LBS

STANDARD FEATURES

- **DIRECT DRIVE TRIPLEX PLUNGER PUMP—GENERAL®**
- **OIL FIRED BURNER - WAYNE®**
OIL FIRED (NO. 1 & NO. 2 DIESEL, KEROSENE, NO. 1 HOME HEATING OIL)
- **NG/LP FIRED BURNER - SOLARFLO®**
- **WHEEL CONFIGURATIONS FOR AV OIL FIRED UNITS**
SOLID CORE FRONT ROTATING CASTER
WITH SOLID CORE REAR AXLE WHEELS
SOLID CORE AXLE WHEELS FRONT AND REAR
SOLID CORE FRONT ROTATING CASTER
WITH REAR PNEUMATIC-TUBE AXLE WHEELS
PNEUMATIC-TUBE AXLE WHEELS FRONT AND REAR
- **FORKLIFT TINES FOR AV NG/LP STATIONARY UNITS**
- **UPSTREAM CHEMICAL INJECTION**
- **SPLIT STAINLESS-STEEL OUTER COIL WRAP**
- **STEEL CHASSIS**
WITH TEXTURED POLYESTER POWDER COAT
- **AV SERIES - FUEL TANK, 9 GALLON CAPACITY**
WITH INTEGRATED CAP GAUGE AND STAINLESS-STEEL DIAL INDICATOR
- **OIL FIRED UNITS - 36' GFCI POWER CORD**
- **TRIGGER GUN CONTROL**
WAND ASSEMBLY WITH COOL GRIPS
- **NOZZLE (15°)**
- **50' HOSE — 3/8" ID**
INSULATED WIRE BRAID HOSE WITH SWIVEL CONNECTOR
- **COIL: SCHEDULE 80**
- **ADJUSTABLE THERMOSTAT**

*Ramteq develops
pressure washers with
one thing in mind — you.
The result is a series of
products incorporating
leading technologies,
highest-quality
components and
unparalleled construction.
These products are
engineered for
reliability, performance
and value. Another series
of products
Simply Done Right.™*

We continue to evolve and enhance our product offerings and therefore pictures, features and specifications reflected on this brochure may vary slightly from current product. These may also vary slightly based on component and manufacturing tolerances. See authorized distributors for manufacturer installed options.

FLORIDA WATER BLAST, INC.
12995 Automobile Blvd. Clearwater, FL 33762
1-800-966-0614 www.floridawaterblast.net