



XVG1300
DIRECT DRIVE
GASOLINE

The XV Gasoline & Electric series are the most innovative pressure washers in the industry. With features such as interchangeable wheel configurations, these products are ideal for industrial and commercial cleaning applications. RAMTEQ's top quality, durable construction provides years of reliability. Designed with the user in mind, RAMTEQ's modular technology supports low operational costs through easy, efficient and effective service and upgrade paths. RAMTEQ products designed and built for performance, dependability and low total cost of ownership.

The XV Series

WORKS

BEST
UNDER
PRESSURE



XVE500
BELT DRIVE
ELECTRIC WITH
OPTIONAL COVER

MODULAR DESIGN

CROSS-LINKED
POLYETHYLENE
FUEL TANKS

WAYNE® BURNER

VARIOUS
WHEEL / MOUNTING
CONFIGURATIONS

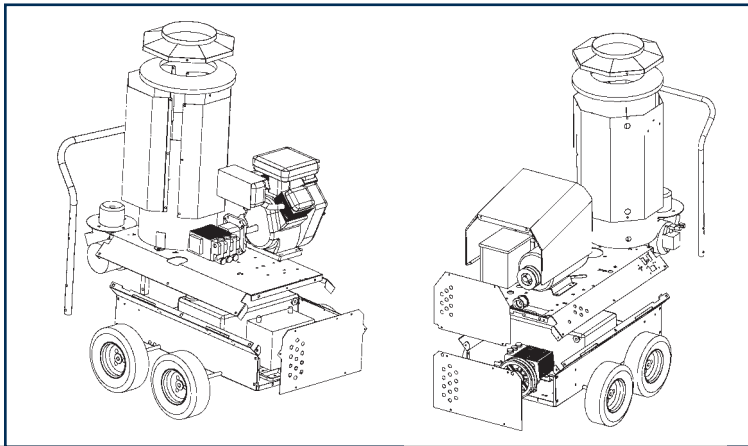

SPLIT STAINLESS-STEEL
OUTER COIL WRAP

TRIPLEX
PLUNGER PUMPS

TEXTURED
POWDERCOAT

FULL CHASSIS
UNDERCARRIAGE

SPECIFICATIONS: GAS & DIESEL

HORSEPOWER
WATER PUMP VOLUME
OPERATING PRESSURE
BTU^s PER HOUR
DIMENSIONS
GROSS SHIPPING WEIGHT

600 SERIES
(DIRECT DRIVE)

6.0 HP
3.0 GPM/11.4 LPM
2000 PSI/137.9 BARS
310,000
43.2"L, 28.5"W, 41.9"H
450 LBS

700 SERIES
(DIRECT DRIVE)

7.0 HP
3.0 GPM/11.4 LPM
2400 PSI/165.5 BARS
310,000
43.2"L, 28.5"W, 41.9"H
450 LBS

900 SERIES
(DIRECT DRIVE)

9 HP
3.5 GPM/13.3 LPM
2500 PSI/172.4 BARS
310,000
43.2"L, 28.5"W, 41.9"H
470 LBS

900 SERIES
(DIRECT DRIVE)

9 HP
3.0 GPM/11.4 LPM
3000 PSI/206.8 BARS
310,000
43.2"L, 28.5"W, 41.9"H
470 LBS

1000 SERIES*
(DIESEL DIRECT DRIVE)

HORSEPOWER
WATER PUMP VOLUME
OPERATING PRESSURE
BTU^s PER HOUR
DIMENSIONS
GROSS SHIPPING WEIGHT

10.0 HP
3.5 GPM/13.3 LPM
3000 PSI/206.8 BARS
310,000
43.2"L, 28.5"W, 41.9"H
530 LBS

1100 SERIES*
(DIRECT DRIVE)

11.0 HP
3.5 GPM/13.3 LPM
3000 PSI/206.8 BARS
310,000
43.2"L, 28.5"W, 41.9"H
470 LBS

1300 SERIES*
(DIRECT DRIVE)

13.0 HP
4.0 GPM/15.2 LPM
3000 PSI/206.8 BARS
310,000
43.2"L, 28.5"W, 41.9"H
485 LBS

1600 SERIES*
(DIRECT DRIVE)

16 HP
4.0 GPM/15.2 LPM
4000 PSI/275.6 BARS
310,000
43.2"L, 28.5"W, 41.9"H
510 LBS

*These units feature electric start

SPECIFICATIONS: ELECTRIC

HORSEPOWER
WATER PUMP VOLUME
OPERATING PRESSURE
BTU^s PER HOUR
DIMENSIONS
GROSS SHIPPING WEIGHT

500 SERIES
(DIRECT DRIVE)

5.0 HP
4.0 GPM/15.2 LPM
2000 PSI/137.9 BARS
310,000
43.2"L, 28.5"W, 41.9"H
430 LBS

500 SERIES
(BELT DRIVE)

5.0 HP
4.0 GPM/15.2 LPM
2000 PSI/137.9 BARS
310,000
43.2"L, 28.5"W, 41.9"H
450 LBS

600 SERIES
(BELT DRIVE)

6.0 HP
4.0 GPM/15.2 LPM
2000 PSI/137.9 BARS
310,000
43.2"L, 28.5"W, 41.9"H
450 LBS

750 SERIES
(BELT DRIVE)

7.5 HP
3.5 GPM/13.3 LPM
3000 PSI/206.8 BARS
310,000
43.2"L, 28.5"W, 41.9"H
510 LBS

XV STANDARD FEATURES:

- TRIPLEX PLUNGER PUMPS
DIRECT DRIVE OR BELT DRIVEN
- BURNER - 110 VOLT OR 12 VOLT
WITH DROPOUT TIMER
OIL FIRED (NO. 1 & NO. 2 DIESEL,
KEROSENE, NO. 1 HOME HEATING OIL)
- HIGH PERFORMANCE ENGINES, MOTORS
- WHEEL CONFIGURATIONS
4 PNEUMATIC AXLE WHEELS
2 PNEUMATICS, 2 FRONT CASTERS
FORKLIFT TINES FOR STATIONARY UNITS
- DETERGENT INJECTION
- SPLIT STAINLESS-STEEL COIL WRAP
- STEEL CHASSIS
WITH TEXTURED POLYESTER POWDER COAT
- FUEL TANK, 9 GALLON CAPACITY
WITH MOLDED POLY CAP AND
STAINLESS STEEL GAUGES
- TRIGGER GUN CONTROL
- NOZZLES (0°, 15°, 25°, 40°)
- 50' HOSE — 3/8" ID
INSULATED SINGLE OR DOUBLE BRAID HOSE
WITH SWIVEL CONNECTOR
- COIL: SCHEDULE 80
- ADJUSTABLE THERMOSTAT

XV OPTIONAL FEATURES:

- UPSTREAM CHEMICAL METERING
WITH POLYETHYLENE FLOAT TANK
AND SINGLE LANCE WAND
REPLACES DOWNSTREAM INJECTION
AND DUAL LANCE WAND
- ROLL CAGE W/ INTEGRATED HANDLE
- CLOSEOUT COVER
FOR ELECTRIC BELT DRIVEN PUMP MODELS

We continue to evolve and enhance our product offerings and therefore pictures, features and specifications reflected on this brochure may vary slightly from current product. These may also vary slightly based on component and manufacturing tolerances. See authorized distributors for manufacturer installed options.

FLORIDA WATER BLAST, INC
12995 Automobile Blvd. Clearwater, FL 33762
1-800-966-0614 - www.floridawaterblast.net