



EH1600
BELT DRIVE
GASOLINE



The EH-CH Gasoline & Diesel series are the most innovative pressure washers in the industry. With a wide range of engines, pumps, pressures, and flow rates available, these products are ideal for industrial and commercial cleaning applications. RAMTEQ's top quality, durable construction provides years of reliability. Designed with the user in mind, RAMTEQ's modular technology supports low operational costs through easy, efficient and effective service and upgrade paths. RAMTEQ products are designed and built for performance, dependability and low total cost of ownership.

The CH & EH Series

WORKS

BEST UNDER PRESSURE



CH1600
BELT DRIVE
WITH OPTIONAL
CLOSEOUT PANEL
& OPTIONAL
PRESSURE GAUGE



MODULAR DESIGN

CROSS-LINKED
POLYETHYLENE
FUEL TANKS

WAYNE® BURNER

STAINLESS-STEEL
OUTER COIL WRAP

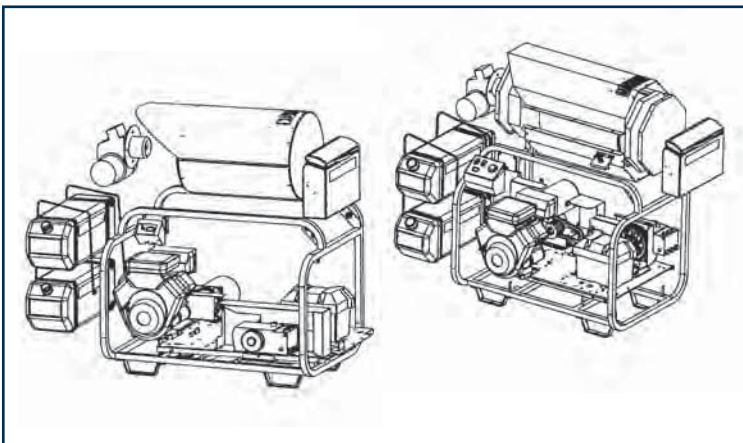

STAINLESS STEEL FUEL
TANK SECUREMENT

TRIPLEX BELT DRIVE
PLUNGER PUMPS

TEXTURED
POWDERCOAT

1¼" SQUARE TUBULAR
STEEL FRAME

SPECIFICATIONS: GAS

HORSEPOWER
WATER PUMP VOLUME
OPERATING PRESSURE
BTU^s PER HOUR
DIMENSIONS
GROSS SHIPPING WEIGHT

1300 SERIES
(BELT DRIVE - HONDA)

13.0 HP
3.5 GPM/13.3 LPM
3500 PSI/241.3 BARS
350,000
46.2"L, 31.0"W, 43.5"H
540 LBS

1600 SERIES
(BELT DRIVE - VANGUARD)

16.0 HP
4.8 GPM/18.2 LPM
3000 PSI/206.8 BARS
350,000
46.2"L, 31.0"W, 43.5"H
560 LBS

1600 SERIES
(BELT DRIVE - VANGUARD)

16.0 HP
4.0 GPM/15.2 LPM
4000 PSI/275.8 BARS
350,000
46.2"L, 31.0"W, 43.5"H
560 lbs

1800 SERIES
(BELT DRIVE - VANGUARD)

18.0 HP
4.8 GPM/18.2 LPM
3500 PSI/241.3 BARS
350,000
46.2"L, 31.0"W, 43.5"H
580 lbs

2000 SERIES
(BELT DRIVE - HONDA)

20.0 HP
5.2 GPM/19.7 LPM
3500 PSI/241.3 BARS
350,000
46.2"L, 31.0"W, 43.5"H
590 LBS

2100 SERIES
(BELT DRIVE - VANGUARD)

21.0 HP
5.2 GPM/19.7 LPM
3500 PSI/241.3 BARS
350,000
46.2"L, 31.0"W, 43.5"H
590 LBS

2100 SERIES
(BELT DRIVE - VANGUARD)

21.0 HP
5.0 GPM/18.9 LPM
4000 PSI/275.8 BARS
350,000
46.2"L, 31.0"W, 43.5"H
610 lbs

2500 SERIES
(BELT DRIVE - KOHLER)

25.0 HP
5.0 GPM/18.9 LPM
4000 PSI/275.8 BARS
350,000
46.2"L, 31.0"W, 43.5"H
630 lbs

*5.0 @ 4000 models use a Comet pump (SW5540S)

SPECIFICATIONS: DIESEL

HORSEPOWER
WATER PUMP VOLUME
OPERATING PRESSURE
BTU^s PER HOUR
DIMENSIONS
GROSS SHIPPING WEIGHT

1000 SERIES
(BELT DRIVE - YANMAR)

10.0 HP
3.5 GPM/13.3 LPM
3000 PSI/206.8 BARS
350,000
46.2"L, 31.0"W, 43.5"H
580 LBS

* ELECTRIC UNITS ARE AVAILABLE ON A CUSTOM ORDER BASIS

STANDARD FEATURES (EH/CH):

- BELT DRIVE TRIPLEX PLUNGER PUMP — GENERAL®, COMET®
- BURNER - WAYNE®
OIL FIRED (NO. 1 & NO. 2 DIESEL, KEROSENE, NO. 1 HOME HEATING OIL)
- GASOLINE ENGINES — VANGUARD®, HONDA®, KOHLER®
- SPLIT STAINLESS-STEEL OUTER COIL WRAP
- 1¼" SQUARE TUBULAR STEEL CHASSIS
WITH TEXTURED POLYESTER POWDER COAT
- COIL: SCHEDULE 80
- FUEL TANKS, 10 GALLON CAPACITY
WITH INTEGRATED CAP GAUGE AND STAINLESS-STEEL DIAL INDICATOR
- 50' HOSE — 3/8" ID
INSULATED SINGLE OR DOUBLE BRAID HOSE WITH SWIVEL CONNECTOR

We continue to evolve and enhance our product offerings and therefore pictures, features and specifications reflected on this brochure may vary slightly from current product. These may also vary slightly based on component and manufacturing tolerances. See authorized distributors for manufacturer installed options.

CH SPECIFIC FEATURES & OPTIONS:

CH SPECIFIC FEATURES:

- COMPRESSED 3" FIBER FIREWALL INSULATION
- COMPRESSED FIBER INSULATION EXHAUST CAP
- SHOCK MOUNTED POWERPLATE
- ADJUSTABLE THERMOSTAT
- FOUR NOZZLES - 0°, 15°, 25° AND 40°
- DOWNSTREAM DETERGENT INJECTOR
- 41" DUAL LANCE WAND

CH OPTIONS:

- UPSTREAM CHEMICAL METERING WITH POLYETHYLENE FLOAT TANK AND SINGLE LANCE WAND (REPLACES DOWNSTREAM INJECTION AND DUAL LANCE WAND)
- CH WHEEL KIT
- STAINLESS FRONT CLOSEOUT PANEL WITH AND WITHOUT PRESSURE GAUGE
- CH SERIES STEAM OPTION

CH UPGRADE PACKAGE:

- GENERATOR WITH WAYNE® 115V BURNER
- HOUR METER
- 50' HOSE — 3/8" ID INSULATED DOUBLE BRAID HOSE WITH SWIVEL CONNECTOR
- UPSTREAM CHEMICAL METERING WITH POLYETHYLENE FLOAT TANK AND SINGLE LANCE WAND (REPLACES DOWNSTREAM CHEMICAL METERING)

EH SPECIFIC FEATURES & OPTIONS:

EH SPECIFIC FEATURES:

- FIXED THERMOSTAT (HIGH TEMP SWITCH)
- ONE NOZZLE - 15°
- UPSTREAM DETERGENT METERING WITH FLOAT TANK
- 36" SINGLE LANCE WAND

EH OPTIONS:

- EH WHEEL KIT
- STAINLESS FRONT CLOSEOUT PANEL WITH AND WITHOUT PRESSURE GAUGE
- ADJUSTABLE THERMOSTAT