

The BV NG/LP Series

WORKS BEST UNDER PRESSURE



BV NG/LP
500, 750



BV NG/LP
1000

Best Engineered

VERSATILITY

The BV gas-fired pressure washers provide high performance with modular design. Available in either NG or LP configurations to allow you to accommodate your individual needs. These products are ideal for industrial and commercial cleaning applications.

SERVICEABILITY

RAMTEQ's top-quality, durable construction provides years of reliability. Designed with the user in mind, RAMTEQ's modular technology supports low operational costs through easy, efficient and effective service and upgrade paths. RAMTEQ products are designed and built for performance, dependability and low total cost of ownership.

VALUE

With RAMTEQ, you get more than just top-of-the-line products with the features and conveniences you want. You also get unmatched customer service and support from a company dedicated to innovative engineering and customer satisfaction.

NO WONDER CUSTOMERS
CHOOSE RAMTEQ.
Its Simply Done Right.™

RAMTEQ[®]
QUALITY PRESSURE WASHERS



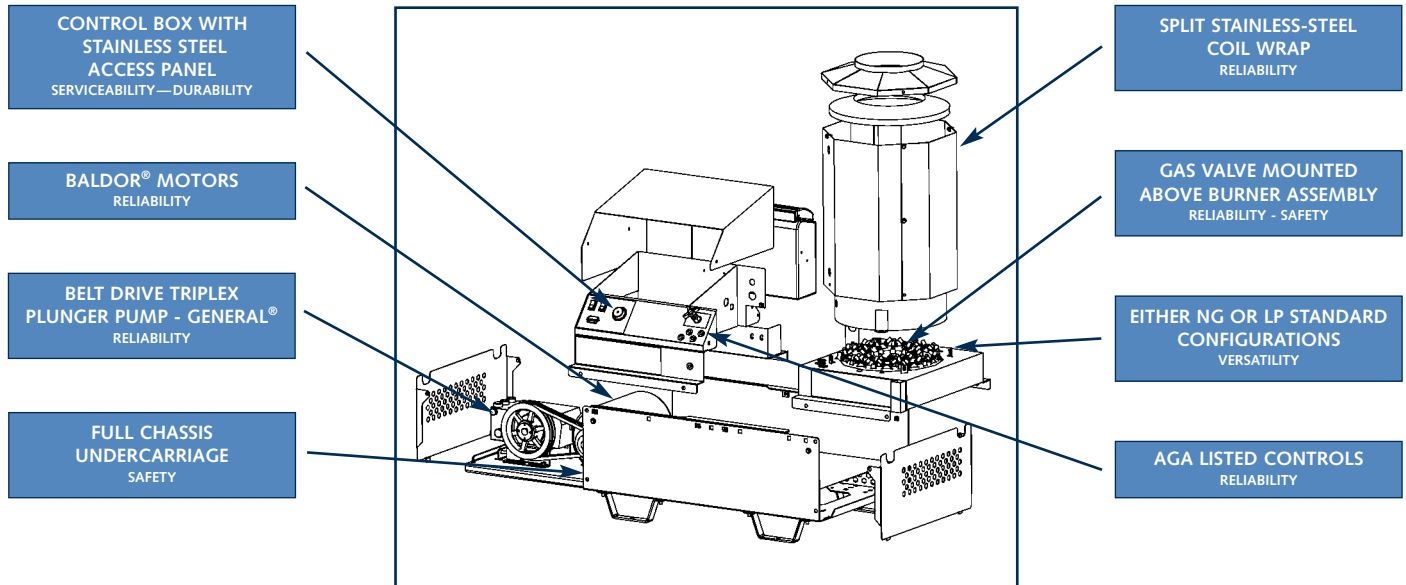

SPECIFICATIONS

	500 SERIES	600 SERIES	750 SERIES	1000 SERIES
MOTOR HP		6.0 HP	7.5 HP	10.0 HP
VOLTAGE/CYCLE/PHASE	208-230/60/1 208-230/60/3 460/60/3	208-230/60/1	208-230/60/1 208-230/60/3 460/60/3	230/60/3 460/60/3
WATER PUMP VOLUME	3.5 GPM/13.3 LPM	4.2 GPM/16.0 LPM	3.5 GPM /13.3 LPM	4.8 GPM/18.2 LPM
OPERATING PRESSURE	2000 PSI/172.4 BARS	2,000 PSI/137.9 BARs	3,000 PSI/206.8 BARS	3,000 PSI/206.8 BARS
BTU^s PER HOUR:(MAXIMUM)	325,000	325,000	325,000	390,000
DIMENSIONS:	40.3"L, 25.1"W, 46.1"H	40.3"L, 25.1"W, 46.1"H	40.3"L, 25.1"W, 46.1"H	40.3"L, 25.1"W, 51.1"H
GROSS SHIPPING WEIGHT:	600 LBS	600 LBS	650 LBS	660 LBS

STANDARD FEATURES

- BELT DRIVE TRIPLEX PLUNGER PUMP—GENERAL®
- NG/LP FIRED BURNER - SOLARFLO®
AGA LISTED CONTROLS -LP VAPOR ONLY
- NATURAL GAS OR LP CONFIGURATIONS STANDARD
- UPSTREAM CHEMICAL INJECTION WITH METERING VALVE
- SPLIT STAINLESS-STEEL OUTER COIL WRAP
- STEEL CHASSIS WITH POWDER COAT PAINT
- POLYETHYLENE FLOAT TANK
- TRIGGER GUN CONTROL
WAND ASSEMBLY WITH COOL GRIPS
- NOZZLES (0°, 15°, 25°, 40°)
- 50' HOSE — 3/8" ID
INSULATED WIRE BRAID HOSE
WITH SWIVEL CONNECTOR
- COIL: SCHEDULE 80
- ADJUSTABLE THERMOSTAT

Ramtec develops pressure washers with one thing in mind — you. The result is a series of products incorporating leading technologies, highest-quality components and unparalleled construction. These products are engineered for reliability, performance and value. Another series of products Simply Done Right.™

UPGRADE PACKAGE (INCLUDES THE FOLLOWING)

- AUTOSTART AND TIME DELAY SHUT DOWN
- MAGNETIC STARTER
- HOUR METER
- INTERMITTENT PILOT IGNITION
- DRAFT DIVERTER
- REMOTE READY

We continue to evolve and enhance our product offerings and therefore pictures, features and specifications reflected on this brochure may vary slightly from current product. These may also vary slightly based on component and manufacturing tolerances. See authorized distributors for manufacturer installed options.